

- Subject : Testing the solarpanel on the fuselage
- Effectivity : DG-800B with solarpanel on the fuselage
- Accomplishment : if needed
- Reason : As the optional solarpanel is not described in the DG-800B manuals, the instructions will be published with this service info.
- Instructions : 1. The solarpanel is installed and wired according to drawing 8E28.
2. If necessary the function of solarpanel and regulator may be tested as follows.
The regulator is installed on the landing gear box, so for the test you have to remove the baggage compartment floors.
a) Panel: Disconnect the plug-socket connections 2 and 3. Connect a Multimeter to both wires coming from the panel. In position V (measuring range 20V) measure the idle-voltage and in position A (measuring range min. 1A, max. 2A) measure the short-circuit current. The measured values are much dependent on the solar radiation. With diffuse light you may measure approx. 15V and 0.1A, with bright vertical radiation you may measure approx. 17V and 0.6A.
Connect the wires again and insulate with heatshrink-tubing or with thermoplastic insulating tape.
b) Regulator.: Disconnect the plug-socket connections 4 and 53. Connect a Multimeter to both wires coming from the regulator. In position A (measuring range min. 1A, max. 2A) measure the short-circuit current. With diffuse light you may measure approx. 0.08A, with bright vertical radiation you may measure approx. 0.5A.
Connect the wires again and insulate with heatshrink-tubing or with thermoplastic insulating tape.

Bruchsal, date:
Febr. 21.2001

Author:
Dipl. Ing. Wilhelm Dirks

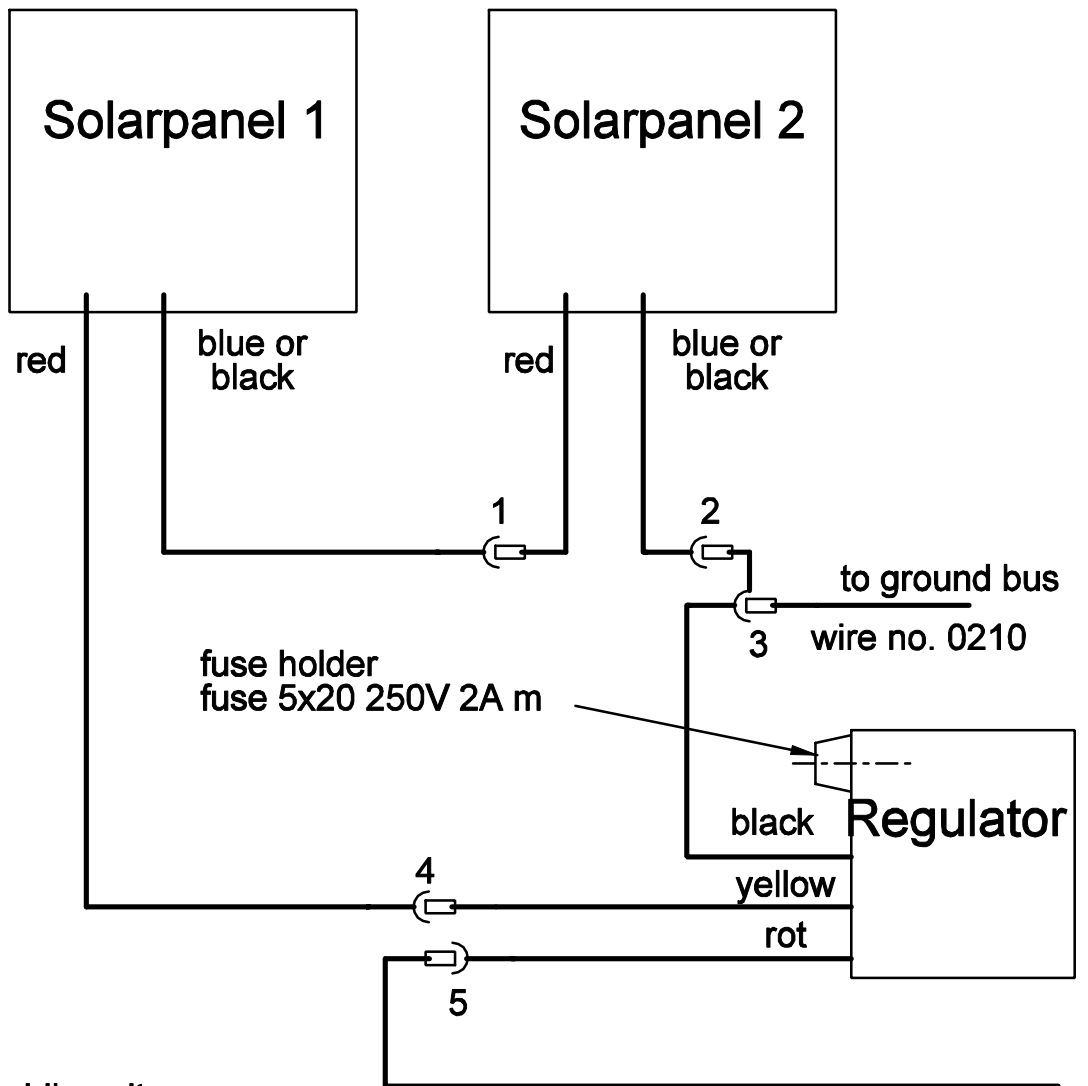

Inspection of the idle voltage:
 Values are for full solar radiation and
 25°C panel temperature.
 Voltage of the panel:
 disconnect plug 3 and 4, 16-18V
 Voltage behind the regulator:
 disconnect plug 3 and 5, 13-14V

to ground bus
 wire no. 0210
 black
 yellow
 rot
 to master switch
 front screwed connection
 wire no. 211
 (together with wire 35/9)

Note: if a charging socket is installed in the rootrib according to installation plan 8EP42 instead of the wire no. 0210 use the wire no. 0210/1 and instead of 211 use 211/1. Connect these wires at the charging socket to the existing wires 0210 and 211. With this installation an additional fuse is installed in a fuse holder in the relays compartment.

Toleranzen nach Arbeitsanweisung BA 1		Tag	Name	DG Flugzeugbau GmbH 76646 Bruchsal Otto-Lilienthal-Weg 2
Schweißen nach Arbeitsanweisung SA 1		Gez.	24.03.00 W. Dirks	
		Gepr.		
		Norm.		
		Maßstab	Solarpanel type Schicke wiring scheme	 8E28
		:		
		:		
		:		
		Maße ohne Toleranz- ang. nach:		
b	inspection added	22.05.02	Dirks	
a	numbering	/	21.02.01 Dirks	
Ausg.	Änderung	ÄM	Tag	Name